

ASPHALT STREET AND DRIVEWAY  
REPLACEMENT REQUIRED FOR  
UTILITY CONSTRUCTION

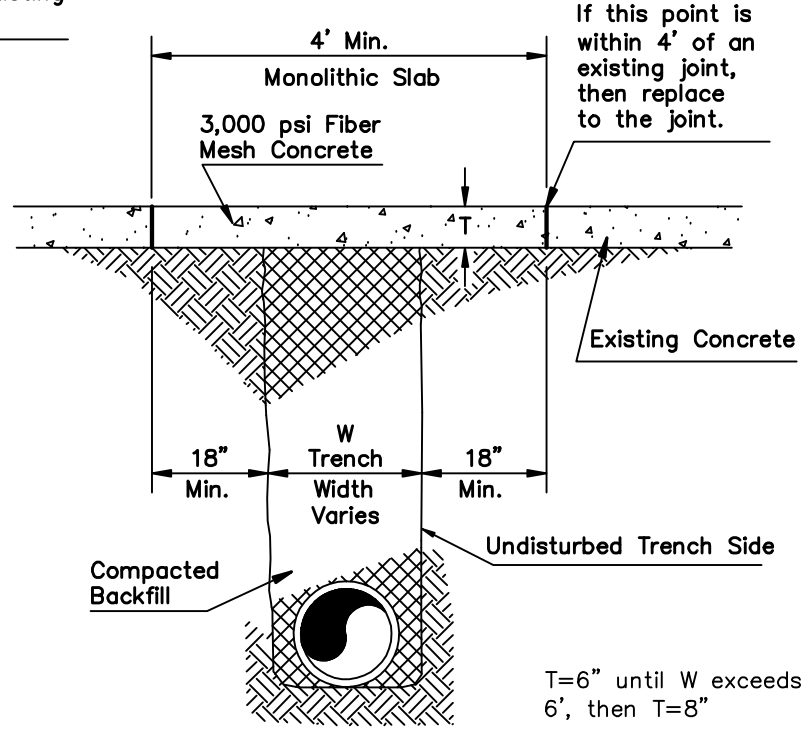

CONCRETE REPLACEMENT REQUIRED  
FOR UTILITY CONSTRUCTION

## STREET AND DRIVEWAY REPLACEMENT FOR CONCRETE & ASPHALTIC CONCRETE SURFACES

CITY INDEX NO. 104; 1 OF 1  
N.T.S.

				CITY OF CLEARWATER, FLORIDA ENGINEERING DEPARTMENT		
				REDRAWN BY Novo	STREET AND DRIVEWAY	DATE 01/09
				CHECKED BY G.L.B.	REPLACEMENT FOR	INDEX NO. 104
REV.	DATE	DESCRIPTION	APP.	DESIGNED BY C.M.H.	CONCRETE & ASPHALTIC CONCRETE SURFACES	1 OF 1