

ISOMETRIC VIEW

If "x" is less than 48" then the slope of the flared side shall not exceed 12:1.

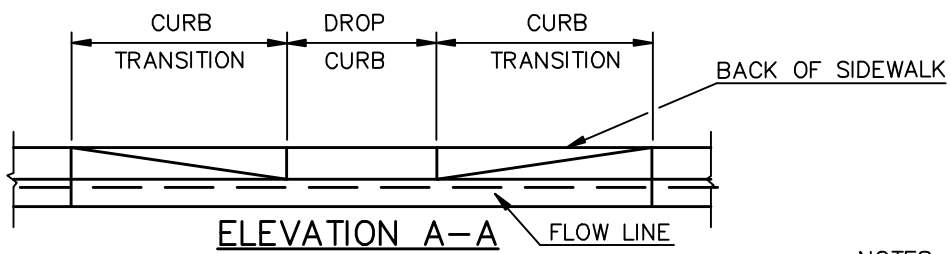

ELEVATION A-A

TYPICAL SIDEWALK CURB CUT RAMPS PHYSICALLY HANDICAPPED

CITY INDEX NO. 109; 2 OF 3
N.T.S.

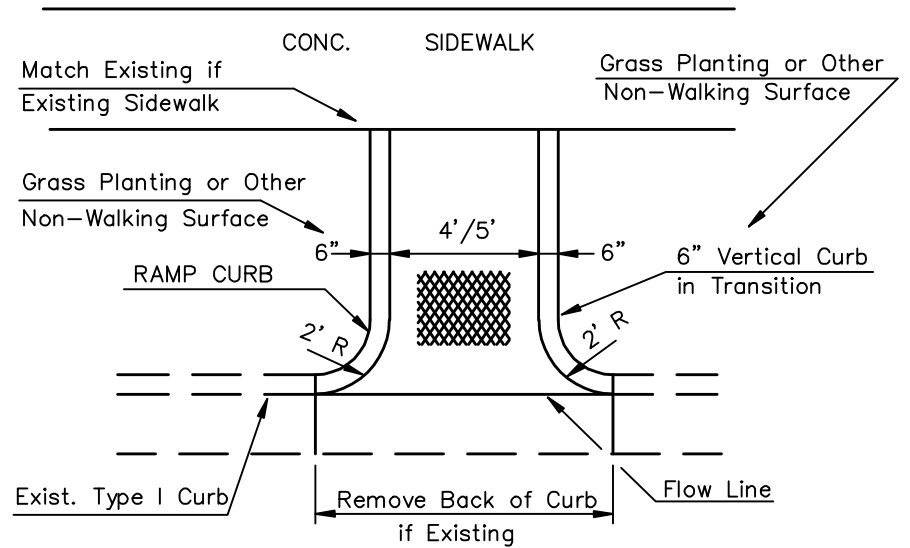

RETURNED CURB RAMPS

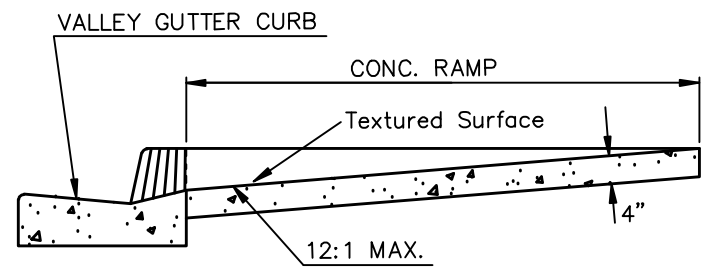

SECTION B-B

NOTES:

1. Ramps are designed to the Uniform Federal Accessibility Standards to comply with the Americans with Disabilities Act.
2. Ramps Shall Have a Tactile Surface, Textured to a Depth Not Exceeding 1/8" by use of Tamp or roller in Conformance with Requirements of FDOT Roadway and Traffic Design Standards, Detail 304 Or Most Recent Modifications.

				CITY OF CLEARWATER, FLORIDA ENGINEERING DEPARTMENT		
				REDRAWN BY P.W.D.	TYPICAL SIDEWALK	DATE 01/09
				CHECKED BY T.C.J.	CURB CUT RAMPS	INDEX NO. 109
				DESIGNED BY C.M.H.	PHYSICALLY HANDICAPPED	
REV.	DATE	DESCRIPTION	APP.			2 OF 3